

Aussie Pumps

Reliable Products ... Reliable People



Fuel Chief Yanmar

AUSSIE QUIK PRIME DIESEL FUEL TRANSFER PUMPS

The Aussie Fuel Chief range of fuel transfer pumps offer high performance and reliability.

Viton seals ensure safe leak free transfer of most aggressive chemicals including fuel oils.

Features

- **Five year pump end warranty**
- **Primes fast** from 7.6 metres
- **Honda petrol or Yanmar diesel engines**
- **Single piece**, heavy duty closed or open impeller
- **Replaceable flanged** suction port & discharge elbow
- **Big belly body**... for fast priming & extra performance
- **Marine grade** aluminium body
- Easy access priming port
- Optional spark arrester

Benefits

- » Great quality ... use with confidence
- » Ready to pump in the minimum amount of time
- » Tried and proven with established service networks throughout the world
- » Pumps more fuel at high pressure
- » Easy to service check valve, allows for option of 2" or 3" ports to be fitted
- » Larger passages mean more efficiency & lower fuel costs
- » Corrosion resistant, long life
- » Convenient & safer
- » For added safety



Fuel Chief Honda

Specifications

HONDA PETROL DRIVE			3 year GX engine warranty				
Inlet/Outlet	Model		HP	Pump PSI	Max Head (m)	Max Flow (lpm)	Frame
2" inlet 3 way outlet 2 x 1" & 1 x 1½"	Fuel Chief Honda	QP205SE	5.5 or 6.5	107	75	450	skids & handle
	Fuel Master 2 Honda	QP209	5.5	47	33	800	roll frame
3" x 3"	Fuel Master 3 Honda	QP303	5.5	45	32	1000	roll frame
			6.5				

YANMAR DIESEL DRIVE			2 year engine warranty				
Inlet/Outlet	Model		HP	Pump PSI	Max Head (m)	Max Flow (lpm)	
2" inlet 3 way outlet 2 x 1" & 1 x 1½"	Fuel Chief Yanmar	QP205SE L48	4.8	85	60	400	
	Fuel Master Yanmar	QP209 L48		40	28 [#]	700 [#]	
3" x 3"	Fuel Master 3" Yanmar	QP303 L48		43	30	1050	

YANMAR OPTIONS....

- Full frame
- Stop/start solenoid
- Emergency stop



All priming & performance data based on water, [#] Performance with 2" outlet

FUEL PUMPS TO 4" ALSO AVAILABLE
(1,500 LPM FLOW) ... CALL FOR DETAILS

Due to our program of continuous product development the manufacturer reserves the right to alter specifications without notice.

Aussie Pumps

Reliable Products ... Reliable People



AUSSIE QUIK PRIME DIESEL FUEL TRANSFER PUMPS

Construction:

Front case	Marine grade aluminium
Volute	Marine grade aluminium
Back plate	Marine grade aluminium
Mechanical seal	Viton®
Outlet	Marine grade aluminium
Casing bolts	Zinc plated steel
Check valve	Viton®
Priming & drain plugs	Polycarbonate
Casing, priming & drain plug o-rings	Viton®
Finish	Brushed aluminium
Impeller	Marine grade aluminium, closed type

Dimensions:

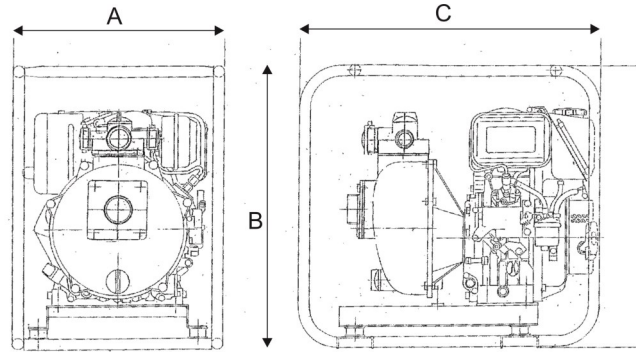

Basic Models (with full frame, no solenoid)	Engine	A Width (mm)	B Height (mm)	C Length (mm)	Weight (kg)
Fuel Master Honda 2"	GX160	542	459	523	30
Fuel Master Honda 3"	GX160	542	459	523	30
Fuel Chief QP205SE Yanmar	L48	445	510	550	58
Fuel Master QP209 Yanmar	L48	445	510	550	58

Models (with skids & handle)

Fuel Chief Honda	GX160 or GX200	393	478	491	30
------------------	----------------	-----	-----	-----	----

Performance Curve:

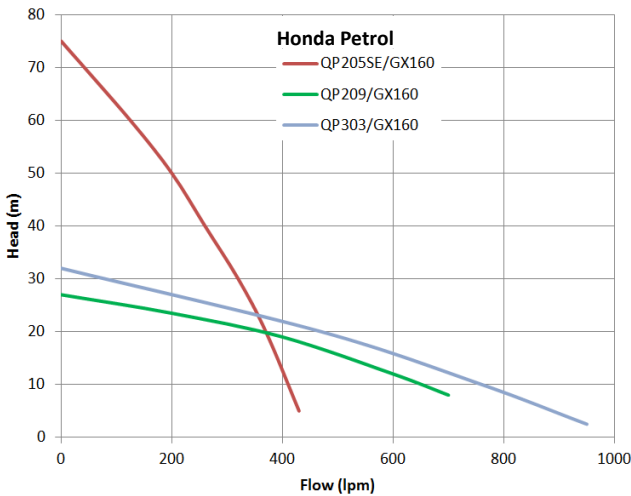

Golden Rule

Operate pump at the best efficiency point
... 85% of max pump head

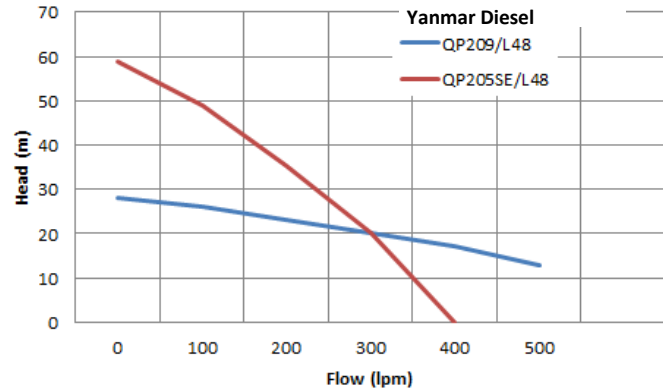

NOTE: performance shown with 2" outlet or 3" outlet, not 3 way tree

For electric drive ATEX certified fuel oil transfer pumps see separate spec sheet



Due to our program of continuous product development the manufacturer reserves the right to alter specifications without notice.